



DMG SpA
Via Quarto Negrone, 10
00040 CECCHINA (ROMA) • ITALIA
Tel. +39 06930251 • Fax +39 0693025240
info@dmg.it • www.dmg.it

Amigo

Emergency Telephone

U.S. version

Installation manual

FCC NOTICE FOR PART 68

This equipment complies with Part 68 of the FCC rules and the requirements adopted by the ACTA. On the outside surface of this equipment there is a label that contains, among other information, a product identifier in the format US:PUM TD 01B ETSOM10. If requested, this number must be provided to the telephone company.

The REN is used to determine the number of devices that may be connected to a telephone line. Excessive RENs on a telephone line may result in the devices not ringing in response to an incoming call. In most but not all areas, the sum of RENs should not exceed five (5.0). To be certain of the number of devices that may be connected to a line, as determined by the total RENs, contact the local telephone company.

If this equipment ETSOM10 causes harm to the telephone network, the telephone company will notify you in advance that temporary discontinuance of service may be required. But if advance notice isn't practical, the telephone company will notify the customer as soon as possible. Also, you will be advised of your right to file a complaint with the FCC if you believe it is necessary.

The telephone company may make changes in its facilities, equipment, operations or procedures that could affect the operation of the equipment. If this happens the telephone company will provide advance notice in order for you to make necessary modifications to maintain uninterrupted service.

If trouble is experienced with this equipment ETSOM10, for repair or warranty information, please contact the service center listed below (see SERVICE CENTER). If the equipment is causing harm to the telephone network, the telephone company may request that you disconnect the equipment until the problem is resolved.

Connection to party line service is subject to state tariffs. Contact the state public utility commission, public service commission or corporation commission for information.

If your home has specially wired alarm equipment connected to the telephone line, ensure the installation of this ETSOM10 does not disable your alarm equipment.

Note that this equipment can be wired to the phone line in a way that allows it to take the line with priority for all outgoing and incoming calls, thereby excluding any other device from the phone line upon pressure of the ON/OFF button. Please refer to §2.4.1 of this installation manual for more information. If you have questions about what will disable alarm equipment, consult your telephone company or a qualified installer.

FCC NOTICE FOR PART 15

This device complies with Part 15 of the FCC Rules. Operation is subject to the following two conditions: (1) this device may not cause harmful interference, and (2) this device must accept any interference received, including interference that may cause undesired operation.

Warning: Changes or modifications to this unit not expressly approved by the party responsible for compliance could void the user's authority to operate the equipment.

Note: This equipment has been tested and found to comply with the limits for a Class B digital device, pursuant to Part 15 of the FCC Rules. These limits are designed to provide reasonable protection against harmful interference when the equipment is operated in a commercial environment. This equipment generates, uses, and can radiate radio frequency energy and, if not installed and used in accordance with the instruction manual, may cause harmful interference to radio communications. Operation of this equipment in a residential area is likely to cause harmful interference in which case the user will be required to correct the interference at his own expense.

SERVICE

MAD Elevator Fixtures Inc.
115 City View Dr.
Etobicoke, Ontario M9W 5A8 Canada
Telephone: (416) 245-8500
Fax: (416) 245-8502
E-Mail: info@madfixtures.com

REGISTRATION

The DMG ETSOM10 series meets FCC part 15, ACTA part 68.

FCC Registration US:PUM TD 01B ETSOM10

Ringer Equivalence Number (REN) = 0.1B



CAUTION:

To reduce the risk of fire, use only No. 26 AWG or larger telecommunication line cord.

ATTENTION:

Pou réduire les risques d'incendie, utiliser uniquement des conducteurs de télécommunications 26 AWG au de section supérieure.

2.3) Operations

After power and line connections, the AMIGO emergency telephone is ready to be used. No other configuration is required.

2.3.1 Making a call

In case of emergency, to make a phone call, press the ON/OFF button on the front keypad, wait of the dialing tone and then dial the desired phone number.

In case of no answer or line busy, the user can press the ON/OFF button and try again, otherwise the line will be automatically disconnected after three minutes.

Once the two-way conversation with the receiving party is established, the user can speak freely for the preset conversation time (5 minutes). A warning beep will advise that the conversation time is about to expire (30 seconds, 15 seconds and 5 seconds before expiration). To extend the conversation time, press any key, otherwise the line will be automatically disconnected and the phone will get back to stand by.

To terminate the phone call, just press the **ON/OFF** button.

Volume can be adjusted by repeatedly pressing the **#** key (3 volume levels available).

2.3.2 Receiving a call (Normal operations)

Under normal conditions, once the AMIGO is connected to the phone line it works exactly as any other device in the house phone loop: upon an incoming call from the outside, it will beep shortly at each ring. To answer the external call, just press the ON/OFF button and talk freely. To close the call, press ON/OFF again.

2.3.3 Receiving a call (After emergencies)

Upon termination of an emergency call originated from within the cabin (see §2.3.1), the AMIGO phone runs into a "Wait for call" mode which will last for 5 minutes. During "Wait for call" an external call is automatically answered by the AMIGO after two rings, without the need to press the ON/OFF button. This feature ensures safer interaction with the passenger in the case this one cannot reach for the keypad.

2.4) Advanced Configurations

2.4.1 Advanced Phone Line Connection

AMIGO can be wired to the phone line in a way that allows it to take the line with priority for all outgoing and incoming calls, thereby excluding any other device from the phone line upon pressure of the ON/OFF button. This configuration is recommended when devices such as automatic answering machine and/or PC modems are connected to the phone line as their presence may cause busy phone line (PC modem) or conflict during incoming calls (answering machine). Generally speaking, this configuration enhances the level of safety of the whole emergency system.

To enable the priority feature, connect the two telephone line wires (Line In) to terminals 7 and 8 of the AMIGO (see figure B) and then use terminals 5 and 6 to connect the following phone device in the loop. Upon pressure of the ON/OFF button and during "Wait for call" mode, an internal switch will automatically disconnect all other devices connected to the line and will give priority to all outgoing and incoming calls from/to the AMIGO emergency phone.

2.4.2 Priority Operations

All operations are identical to what described in §2.3. The only differences are the following:

- When the ON/OFF button is pressed to make a call, any other device connected to the phone line is automatically disconnected from the line (Priority on outgoing calls).
- After emergency ("Wait for call" mode, 5 minutes), any other device in the house remains disconnected and incoming call are automatically forwarded to the lift car phone.

Note: "Wait for call" mode can be terminated even before the 5 minutes period by entering a reset code ("1234") on the keypad. This will put the AMIGO back to stand-by and will reconnect the other devices to the phone line.

2) Power Connection

2.1) Power Connection

The AMIGO emergency phone must be powered through an independent power source (different from the phone line) and its operation must be ensured also in case of main power failure. This can be accomplished in two different ways:

A) 12-24V DC Power supply with emergency rechargeable battery

In case an emergency power source is provided by the elevator controller through emergency rechargeable batteries, just connect power supply to wire terminals 1 and 2 (*see figure A*).

B) 18-24V DC Power supply without rechargeable battery

In case no emergency power source is available, it is recommended to add an external rechargeable NiMh battery pack (12V 60mAH) to ensure proper functioning in case of power failure. The power supply must be connected to wire terminals 1 and 2 of the emergency telephone and the additional battery to terminals 3 and 4 (*see figure below*).

The NiMh battery pack has 3h of autonomy in stand-by and 20m in conversation mode. Wire terminals 3 and 4 of the AMIGO telephone provide the needed supply (12h recharging time).

The battery pack is small enough to be inserted anywhere behind the car operating panel.

2.2) Phone Line Connection

Connect the two telephone line wires (Line In) to terminals 7 and 8 of the AMIGO (*see figure A*) and then use the same terminals to connect the following phone device in the loop.

In such configuration the AMIGO emergency phone is connected to the telephone line in parallel with other devices in the house and will work exactly as a phone device (no priority on outgoing and incoming calls). Therefore, outgoing calls are possible only if the line is not busy and external calls may also be taken from any other device in the house.

Figure A
Power Supply and Line Connections

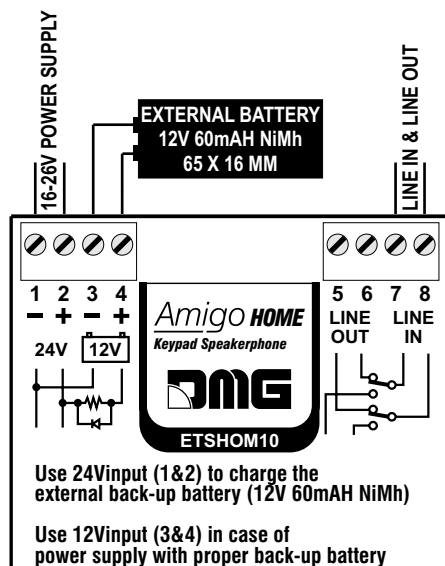
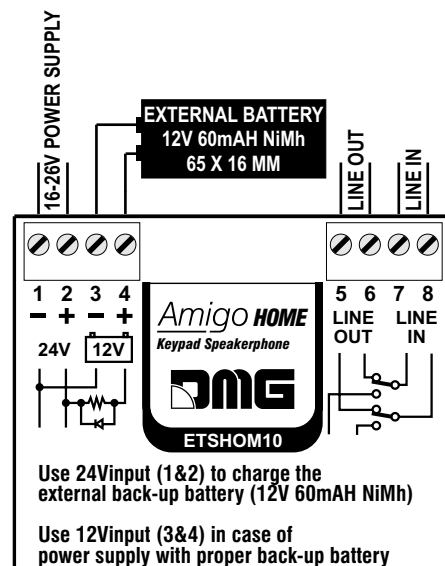

Figure B
Advanced Phone Line Connection



1) Installation instructions page **4**

1.1 Gilda plate 100mm 4

1.2 Flat plate and Gilda plate 200 mm 5

2) Connections page **6**

2.1 Power Connection 6

2.2 Phone Line Connection 6

2.3 Operations 7

2.4 Advanced Configurations 7

1) Installation instructions

The Emergency Telephone can be inserted in the following plates:

1.1) Gilda plate 100 mm

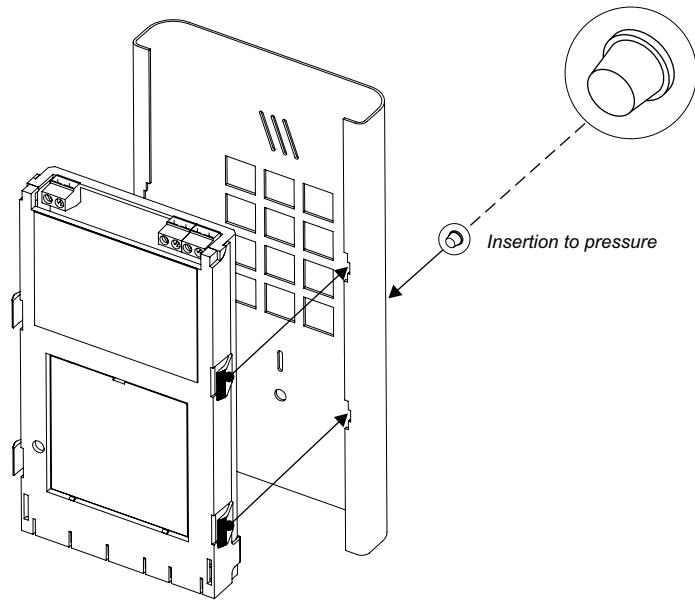

1.2) Flat plate and Gilda plate 200 mm

