

**Put a  
telephone  
in your homelift!**

*FCC-compliant*

**Amigo**



**Keypad Emergency Telephone for Homelifts**

*Electronic devices*

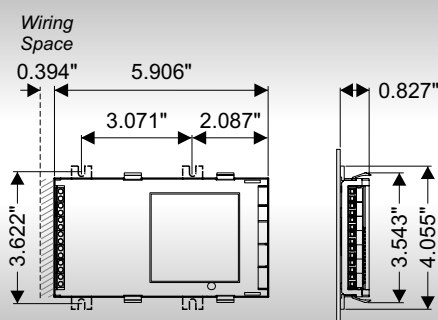

**Fixing on Gilda faceplates**

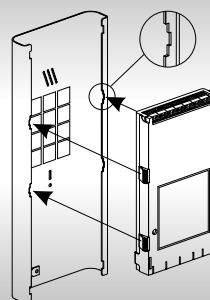

- ✓ Easy installation in the lift car on 100mm Gilda surface mounted plates
- ✓ Ultrathin size (0,82"), fits to any car operating panel
- ✓ Works like a traditional telephone connected to house phone line
- ✓ Hook up line LED, adjustable volume
- ✓ 5 seconds conversation time (extendable)
- ✓ 12-24V DC power supply with separate backup battery
- ✓ Possibility to run in priority mode on both incoming and outgoing calls

E\_amigo-fcc\_060908-0\_eu\_EN.cdr

**MAD Elevator Fixtures Inc.**  
 115 City View Drive  
 Etobicoke, Ontario  
 M9W 5A8 Canada  
 Telephone: (416) 245-8500  
 Fax: (416) 245-8502  
 info@madfixtures.com  
 www.madfixtures.com