



D4
Lampada di emergenza
Emergency light
Eclairage de secours
Notlicht
Lámpara de emergencia



Manuale di installazione
Installation manual / Notice technique
Installationshandbuch / Manual de Instalación



DMG SpA
Via Quarto Negrone, 10
00040 CECCHINA (ROMA) • ITALIA
Tel. +39 06930251 • Fax +39 0693025240
info@dmg.it • www.dmg.it

92010003_C_lampada-emerg.D4_071105-0__ed.1.cdr



D4
Lampada di emergenza
Emergency light
Eclairage de secours
Notlicht
Lámpara de emergencia



Manuale di installazione
Installation manual / Notice technique
Installationshandbuch / Manual de Instalación



DMG SpA
Via Quarto Negrone, 10
00040 CECCHINA (ROMA) • ITALIA
Tel. +39 06930251 • Fax +39 0693025240
info@dmg.it • www.dmg.it

92010003_C_lampada-emerg.D4_071105-0__ed.1.cdr

Istruzioni di montaggio
Installation instruction - Instruction pour le montage
Montageanleitung - Instrucciones de montaje

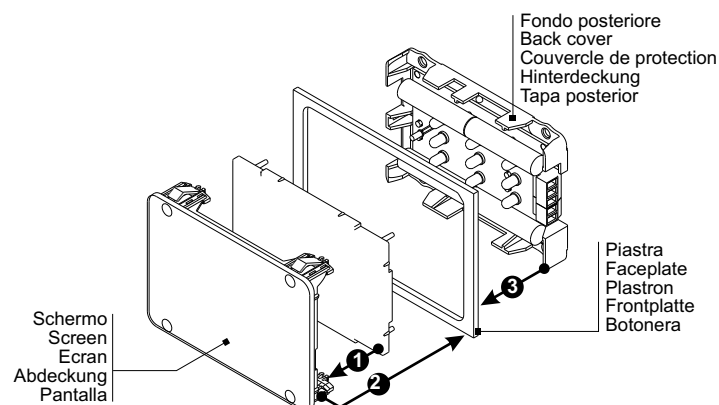
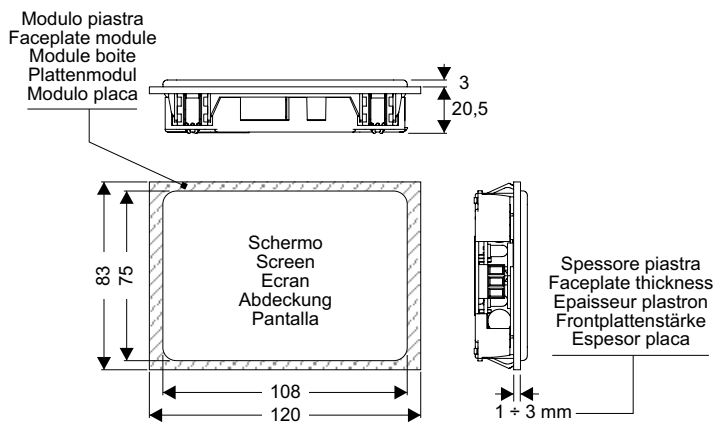

Schemi elettrici
Wiring diagram - Schémas électriques
Elektrische Schemas - Esquemas eléctricos

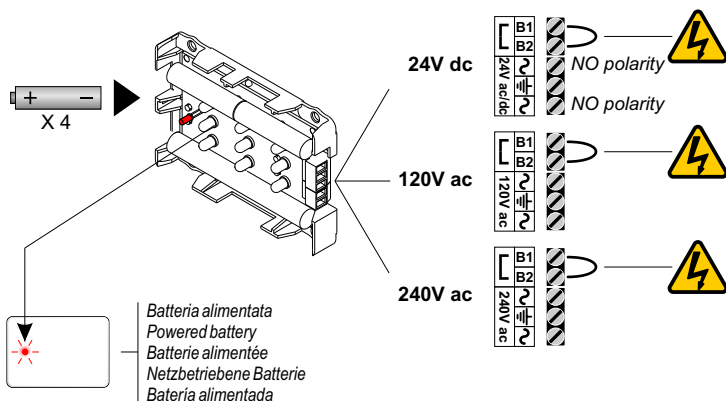
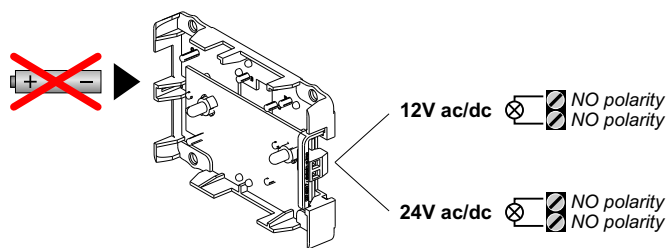

Batteria alimentata
 Powered battery
 Batterie alimentée
 Netzbetriebene Batterie
 Bateria alimentada

Collegare tra loro i morsetti B1 e B2 prima di alimentare la lampada di emergenza e NON scollegarli quando questa è collegata all'alimentazione.

Before powering the emergency lamp, connect B1 and B2 screw terminals together and DO NOT disconnect them as long as it is powered.

Brancher les bornes à vis B1 et B2 entre eux avant d'alimenter l'éclairage de secours et ne pas les débrancher pendant qu'il est alimenté.

Bevor die Notlichter zu versorgen, die Klemmen B1 und B2 miteinander anschließen. Diese Anschließung behalten auch während Versorgung des Notlichts.

Conectar entre ellos los bornes B1 y B2 antes de alimentar la lámpara de emergencia y NO los desconectes cuando ésta está conectada a la alimentación.

Istruzioni di montaggio
Installation instruction - Instruction pour le montage
Montageanleitung - Instrucciones de montaje

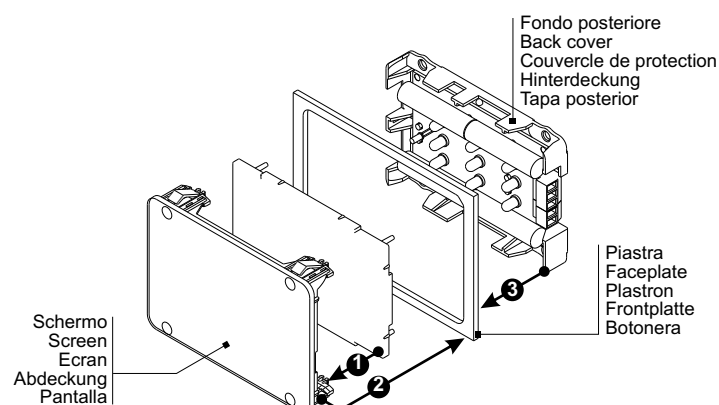
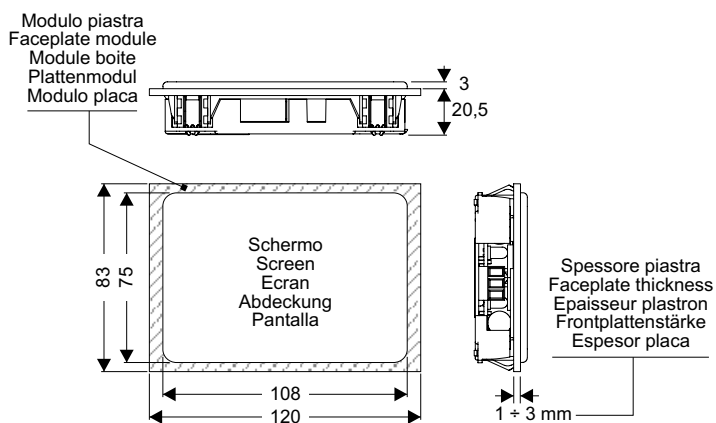

Schemi elettrici
Wiring diagram - Schémas électriques
Elektrische Schemas - Esquemas eléctricos

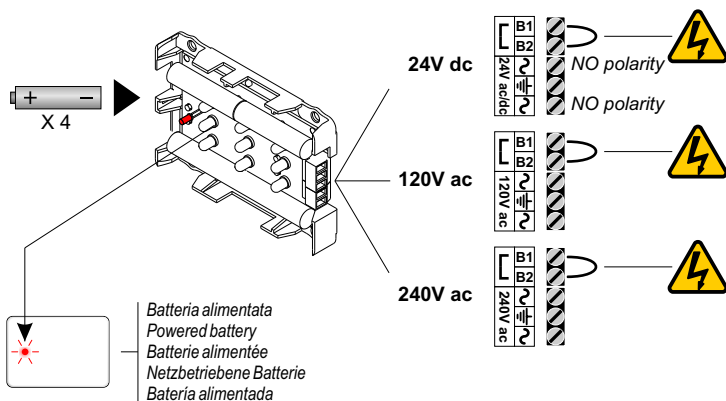
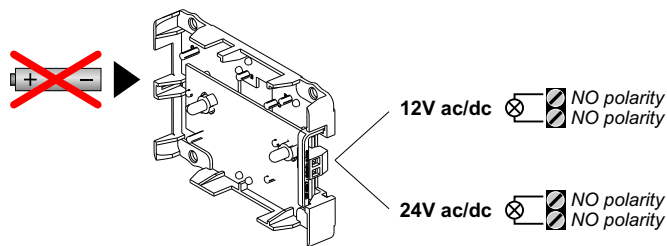

Batteria alimentata
 Powered battery
 Batterie alimentée
 Netzbetriebene Batterie
 Bateria alimentada

Collegare tra loro i morsetti B1 e B2 prima di alimentare la lampada di emergenza e NON scollegarli quando questa è collegata all'alimentazione.

Before powering the emergency lamp, connect B1 and B2 screw terminals together and DO NOT disconnect them as long as it is powered.

Brancher les bornes à vis B1 et B2 entre eux avant d'alimenter l'éclairage de secours et ne pas les débrancher pendant qu'il est alimenté.

Bevor die Notlichter zu versorgen, die Klemmen B1 und B2 miteinander anschließen. Diese Anschließung behalten auch während Versorgung des Notlichts.

Conectar entre ellos los bornes B1 y B2 antes de alimentar la lámpara de emergencia y NO los desconectes cuando ésta está conectada a la alimentación.